

Article number: 2302169197

Description: E+G Stjernegreb VCRT.63 FP-M10

Measures

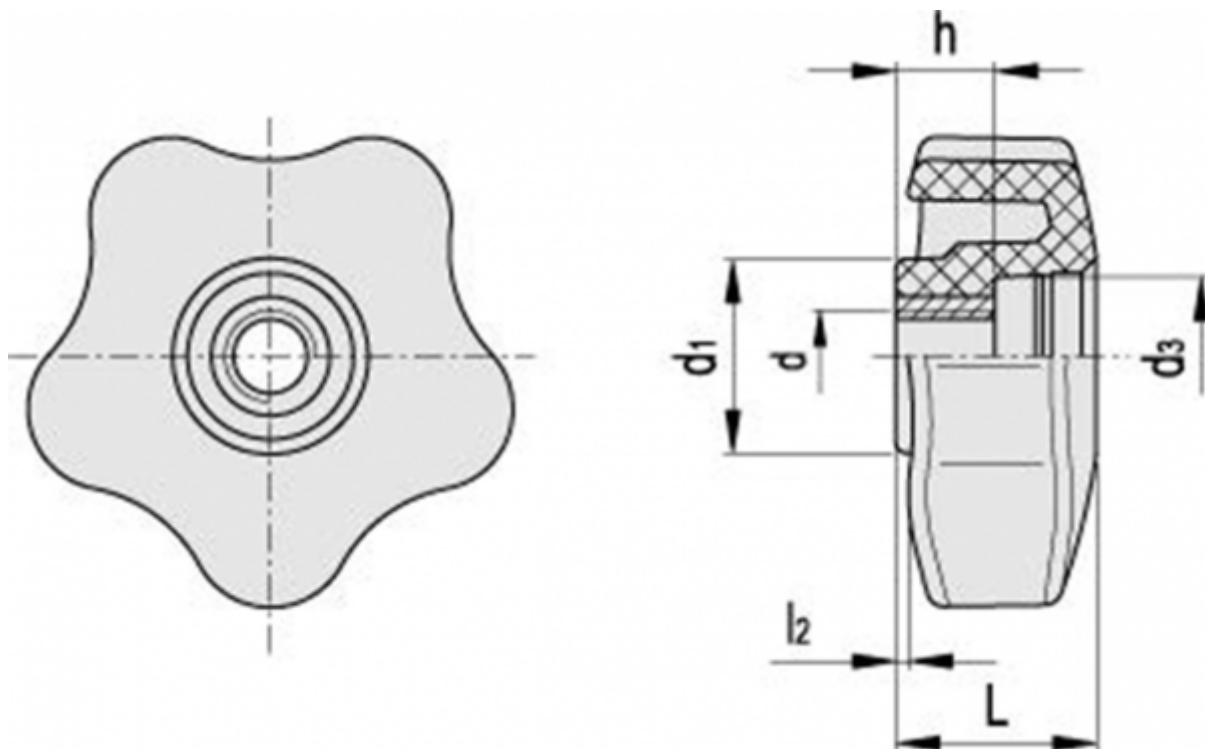

D	= 63
d1	= 22.5
d3	= 19.5
dh	= 10
h	= 15
l2	= 1.3
L	= 21.5
Weight in (g)	= 35